

# PFA

## TUBE AND FITTINGS

This industrial grade flexible tubing system is manufactured PFA. Although similar to PTFE, PFA is mechanically superior, has 1/10th the creep characteristics, and is transparent. The most common usage for this material is chemical dosing, where transportation of highly corrosive chemicals are used.

PFA fittings are specifically designed, tested and characterized to work together with industrial grade PFA tube. Fittings are connected to the tube by first heating the end of the tube with a hot air gun and expanding or flaring the end of the tube using a flaring mandrel.

This flared end is then inserted into the fitting body before tightening the nut.

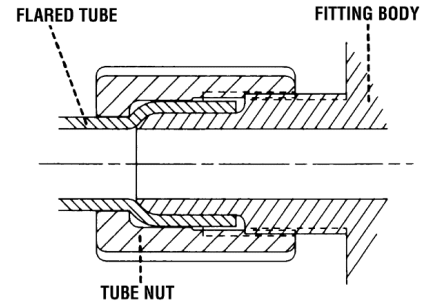

### Assembly Instructions

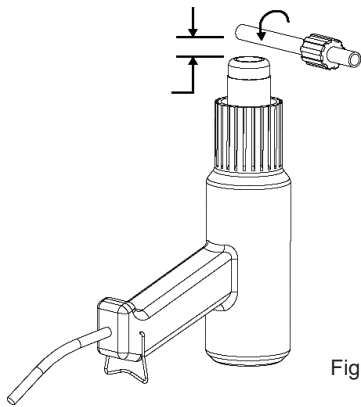

Figure 1

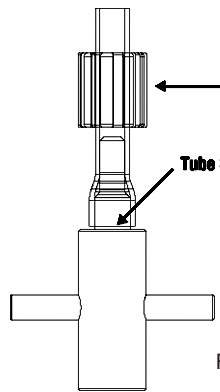

Figure 2

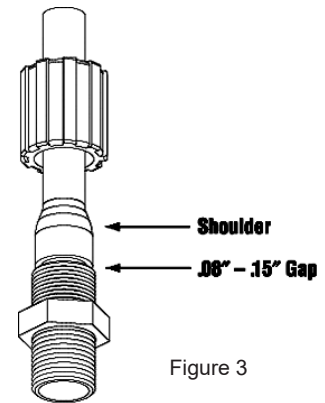



Figure 3

### Heat Flaring Instructions

The flaring process provides a permanent expansion (flare) of the tubing end, allowing insertion of the fitting body. Proper tube flaring and fitting assembly results in a very secure tubing connection.

1. Set the hot air gun on "High". Hold the PFA tubing end flush with the heater edge and 1/2" to 3/4" above the heater (see Figure 1) and slowly rotate the tubing 360° for 25 seconds, or until a fine, clear line appears around the tubing.  
Note: It is very important to fully rotate the tubing over the heat source so all surface areas receive an equal amount of heat. Uniform heating is essential to making a good flare.
2. Remove the PFA tubing from the heat source. Immediately push the flaring mandrel (see Figure 2) into the tubing until the end of the tubing reaches the tube stop.
3. Firmly hold the tubing onto the mandrel for 20 seconds
4. Let the flared tubing continue to cool on the mandrel for 2 minutes for 3/8" tubing or 3 minutes for 1/2" and 3/4" tubing.
5. The flaring process is now complete and the mandrel may be removed from the tube.
6. Push the flared tubing end onto the fitting body until the end of the fitting body contacts the flare shoulder of the tube (see Figure 3). The maximum gap between the tube end and end of threads should be .08 - .15".
7. Tighten the nut onto the fitting body until handtight.

## PFA INDUSTRIAL GRADE TUBE

	Code	Size (OD)	ID
 <p>Sold by the metre, available in coil lengths up to 100 metres</p>	TPFATUBE/008	1/4"	3.95mm
	TPFATUBE/010	3/8"	6.33mm
	TPFATUBE/015	1/2"	9.5mm
	TPFATUBE/020	3/4"	15.85mm
	TPFATUBE/025	1"	22.2mm

## PFA

### TUBE & FITTINGS

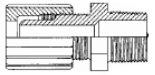
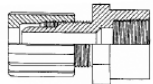
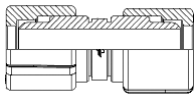
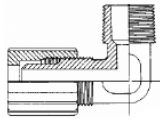
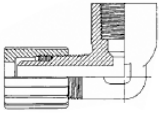
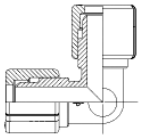
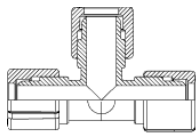
PFA FLARE FITTINGS							
	Code	Size (OD x NPT)			Code	Size (OD x NPT)	
<b>Male Adaptor</b>    NPT Thread	FPFAMADPT/008x1/4	1/4" x 1/4"					
	FPFAMADPT/010x1/2	3/8" x 1/2"					
	FPFAMADPT/010x1/4	3/8" x 1/4"					
	FPFAMADPT/010x3/8	3/8" x 3/8"					
	FPFAMADPT/015x1/2	1/2" x 1/2"					
	FPFAMADPT/015x1/4	1/2" x 1/4"					
	FPFAMADPT/015x3/8	1/2" x 3/8"					
	FPFAMADPT/020x1/2	3/4" x 1/2"					
	FPFAMADPT/020x3/4	3/4" x 3/4"					
	FPFAMADPT/025x1	1" x 1"					
	FPFAMADPT/025x1/2	1" x 1/2"					
	FPFAMADPT/025x3/4	1" x 3/4"					
	<b>Female Adaptor</b>    NPT Thread	FPFAFMADPT/008x1/4					1/4" x 1/4"
		FPFAFMADPT/010x1/4					3/8" x 1/4"
		FPFAFMADPT/010x3/8					3/8" x 3/8"
FPFAFMADPT/015x1/2		1/2" x 1/2"					
FPFAFMADPT/015x3/8		1/2" x 3/8"					
FPFAFMADPT/020x1/2		3/4" x 1/2"					
FPFAFMADPT/020x3/4		3/4" x 3/4"					
FPFAFMADPT/025x1		1" x 1"					
FPFAFMADPT/025x1/2		1" x 1/2"					
FPFAFMADPT/025x3/4		1" x 3/4"					
<b>Straight Union</b>  		FPFASOUN/008	1/4"				
		FPFASOUN/010	3/8"				
		FPFASOUN/015	1/2"				
		FPFASOUN/020	3/4"				
		FPFASOUN/025	1"				
<b>Male Adaptor with BSP thread</b>	FPFAMADPTBSP/015X1/2	1/2" x 1/2"					
	FPFAMADPTBSP/015X3/4	1/2" x 3/4"					
	FPFAMADPTBSP/020X1/2	3/4" x 1/2"					
	FPFAMADPTBSP/020X3/4	3/4" x 3/4"					
	FPFAMADPTBSP/025X1	1" x 1"					
<b>Male Elbow</b>    NPT Thread	FPFAMEL90/008x1/4	1/4" x 1/4"					
	FPFAMEL90/010x1/4	3/8" x 1/4"					
	FPFAMEL90/010x3/8	3/8" x 3/8"					
	FPFAMEL90/015x1/2	1/2" x 1/2"					
	FPFAMEL90/015x3/8	1/2" x 3/8"					
	FPFAMEL90/020x1/2	3/4" x 1/2"					
	FPFAMEL90/020x3/4	3/4" x 3/4"					
	FPFAMEL90/020x3/8	3/4" x 3/8"					
	FPFAMEL90/025x1	1" x 1"					
	FPFAMEL90/025x1/2	1" x 1/2"					
	FPFAMEL90/025x3/4	1" x 3/4"					
	<b>Female Elbow</b>    NPT Thread	FPFAFEL90/008x1/4					1/4" x 1/4"
		FPFAFEL90/010x1/4					3/8" x 1/4"
		FPFAFEL90/010x3/8					3/8" x 3/8"
		FPFAFEL90/015x1/2					1/2" x 1/2"
FPFAFEL90/015x3/8		1/2" x 3/8"					
FPFAFEL90/020x1/2		3/4" x 1/2"					
FPFAFEL90/020x3/4		3/4" x 3/4"					
FPFAFEL90/020x3/8		3/4" x 3/8"					
FPFAFEL90/025x1		1" x 1"					
FPFAFEL90/025x1/2		1" x 1/2"					
FPFAFEL90/025x3/4		1" x 3/4"					
<b>Union Elbow</b>  		FPFAEL90/008	1/4"				
		FPFAEL90/010	3/8"				
		FPFAEL90/015	1/2"				
		FPFAEL90/020	3/4"				
	FPFAEL90/025	1"					
<b>Union Tee</b>  	FPFATEE/008	1/4"					
	FPFATEE/010	3/8"					
	FPFATEE/015	1/2"					
	FPFATEE/020	3/4"					
	FPFATEE/025	1"					

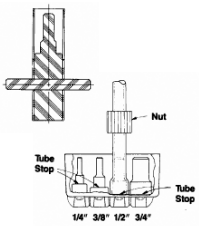
PFA TOOLING		
	Code	Size (OD)
<b>Flare Tools</b>  	FPFAFLARETOOL/008	1/4"
	FPFAFLARETOOL/010	3/8"
	FPFAFLARETOOL/015	1/2"
	FPFAFLARETOOL/020	3/4"
	FPFAFLARETOOL/025	1"

PFA VALVING

<p><b>A RANGE OF PFA VALVES ARE AVAILABLE ON REQUEST</b></p>